



J P King  
Manager  
Parts and Service Engineering  
Ford Parts and Service Division

Ford Motor Company  
3000 Schaefer Road  
P.O. Box 1902  
Dearborn, Michigan 48121

September, 1990

Serial Number IFMCA11S6XYZ12345

Mr. John Sample  
123 Main Street  
Anywhere, USA 12345

Ford Motor Company is providing a no-charge Service Program, number "M70", to owners of certain 1986-87 model Ranger and Bronco II trucks equipped with Mazda five-speed manual transmissions.

REASON FOR  
THIS PROGRAM

On some of these trucks, the transmission shift lever housing may break. If this happens, the driver would not be able to shift the transmission.

At no cost to you, your dealer will replace the broken shift lever assembly before your truck is six years old or before it has 60,000 miles.

If your truck has more than 60,000 miles, this service will be in effect through January 31, 1991.

WHAT YOU  
SHOULD DO

PLEASE KEEP THIS LETTER.

If you have to bring your truck in for this service, give the dealer this letter.

If you misplace this letter, your dealer will still do the work, free of charge.

REFUNDS

If you paid to have this service done before the date of this letter, Ford is offering a full refund, including deductible costs. For a refund, please show your paid work-order or parts receipt to your Ford dealer.

We are taking this action as part of our ongoing efforts to maintain owner confidence in our products. We hope this program will confirm your continued satisfaction in your Ford built truck.

Sincerely,

020095

## OWNER NOTIFICATION PROGRAM M70

LABOR ALLOWANCES

	Hours	Operation
Replace Transmission Shift Lever Assembly.....	1.5	M70

PARTS REQUIREMENTS

Parts will not be direct shipped for this program.  
Order your parts requirements through normal order processing channels.

<u>PART NUMBER</u>	<u>DESCRIPTION</u>	<u>CLASS</u>	<u>DEALER PRICE</u>
E7TZ-7210-S	Kit, Shift Lever Assembly	BG	\$ 23.38

Parts prices current until next issue of Master Price Book. For latest prices, check or call your:

- ° Order Processing Center
- ° DOES II
- ° Updated Price Book.

CLAIMS PREPARATIONS

- ° Use Form 1863
- ° Enter using DWE
- ° Use code information shown below:

Program Code	- M70
Causal Basic Part Number	- 7210
Condition Code	- 01
Labor operation	- M70

OWNER NOTIFICATION PROGRAM M70  
TRANSMISSION SHIFT LEVER REPLACEMENT

TECHNICAL INSTRUCTIONS

REMOVAL

1. Set the Parking Brake.
2. Place the transmission in neutral.
3. Remove the front seats. Refer to the 1987 Truck Shop Manual, Section 41-01 for the procedures.
4. Remove the screws retaining the RH and LH door sill scuff plates and remove the scuff plates.
5. Remove the screws retaining the RH and LH cowl side trim panels and remove the trim panels.
6. Remove the seat belt attachments.
7. Pull the carpet/mat over the shift lever and position it out of the way.
8. Remove the four shift lever boot-to-floor pan attaching screws. (See Figure 1).
9. Remove the four bolts securing the shift lever assembly to the transmission. (See Figure 2). Discard the bolts.
10. Lift the shift lever (with knob and boot) straight up out of the transmission.
11. Cover the transmission opening with a rag to prevent lubricant contamination.
12. Secure the shift lever in a vice. Place an open-end wrench at the base of the shift knob and strike with a rubber mallet to remove the knob. Slide the shift boot off the end of the lever.
13. Save the boot and knob for re-installation. Discard the shift lever assembly.

INSTALLATION

1. Clean the shift lever mounting surface on the transmission.
2. Remove the rag from the transmission opening.
3. Be sure the shift rail socket is positioned vertically and place the functional end of the new shift lever into the transmission shift rail socket.
4. Install four new shift lever attaching bolts and tighten to 7-10 ft-lbs (10-14 N.m).
5. Depress the clutch pedal and slowly shift the transmission into all gears. If lever is not free to move, or moves without engaging the transmission gears, remove the shift lever attachment bolts and pull the shift lever assembly straight up out of the transmission. Repeat step #3.
6. Place the shift lever boot over the shift lever and secure to floor pan with the four screws previously removed.
7. Reposition the carpet or mat.
8. Install the cowl side trim panels and scuff plates.
9. Install the seats.
10. Install the seat belt attachment bolts. Tighten the bolts to 22-32 ft-lbs (29-43 N.m).
11. Place the shift lever knob in the proper position on the end of the lever. With a rubber mallet, strike the top of the knob lightly until securely seated on the shift lever.

# 1986/1987 RANGER AND BRONCO II MANUAL TRANSMISSION SHIFT LEVER REPLACEMENT PROCEDURE

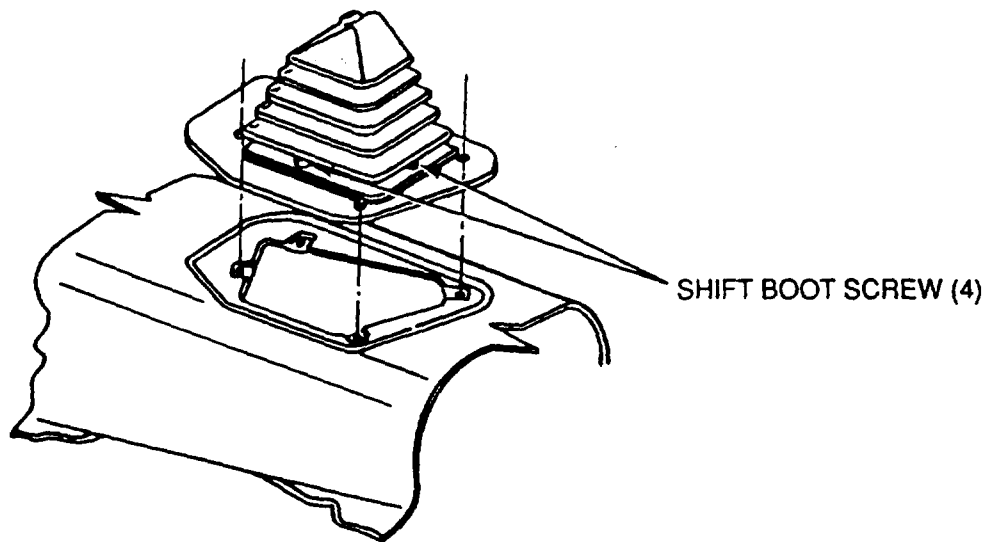

FIGURE 1

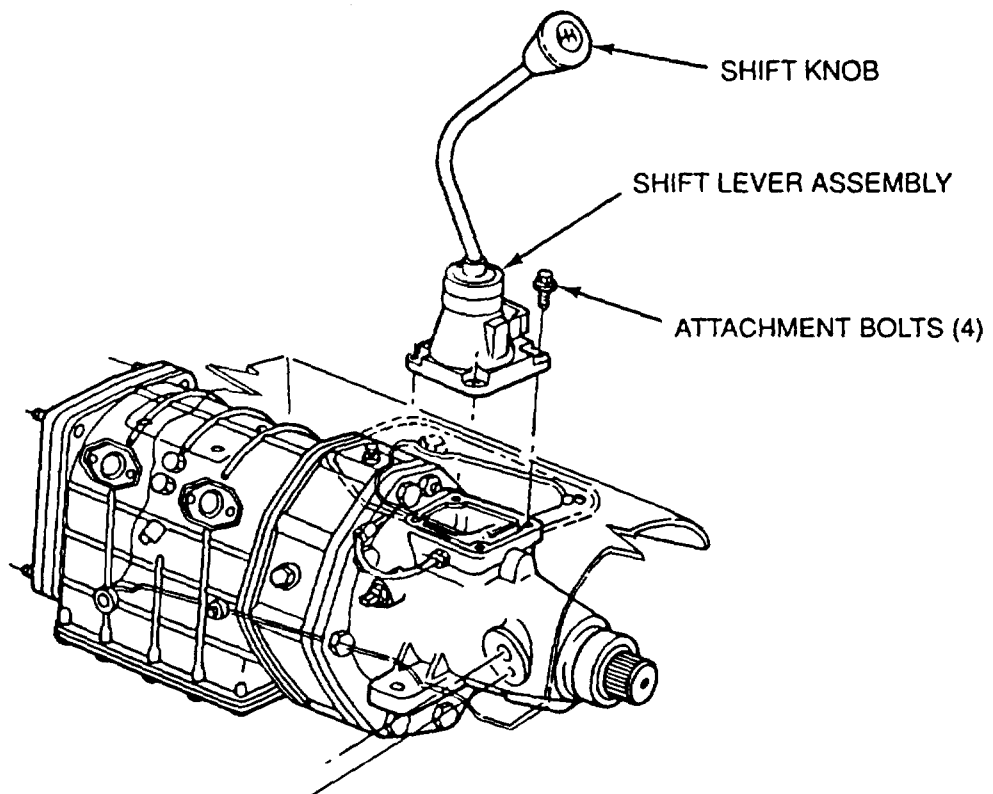

FIGURE 2